



INPRO/SEAL[®]

INSTALLATION INSTRUCTIONS

- 1- Use a hand arbor press to install the assembly into the cover. Check for proper orientation (verify the port is down). Do not insert past location stop or shoulder, if present. Some isolators have an interference with the cover bore.
- 2- Lightly lube the shaft with the supplied lubricant.
- 3- Slide the cover and isolator together over the shaft and into position. Push on the outboard face of the isolator.
- 4- Verify that the shaft turns freely.
- 5- Individual equipment necessitate variations on this procedure.
- 6- Consult www.inpro-seal.com/install.wmv to download a video illustrating a sample installation or consult your authorized Inpro/Seal Representative with any questions.

NOTE- Not all features may be present on your particular design.

NOTE- The isolator is a one-piece assembly. Don't try to separate the parts.

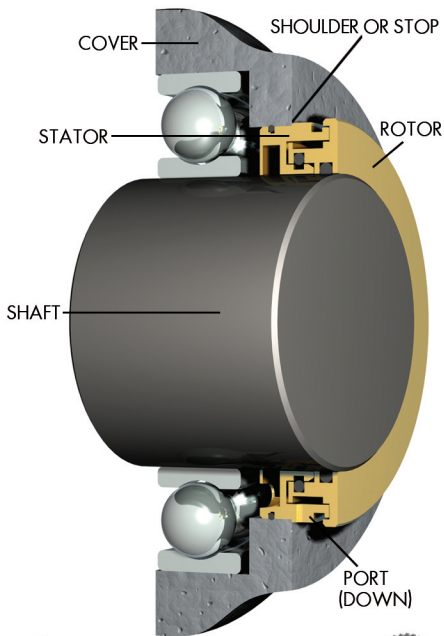

INPRO/SEAL[®] COMPANY

ph- 800.447.0524 • fx- 309.787.6114

info@inpro-seal.com • www.inpro-seal.com

